

# Design, Development and Fabrication of Multipurpose Agro Machine

<sup>[1]</sup> Prashanth S.R, <sup>[2]</sup> Punith S, <sup>[3]</sup> Ashoka Raja, <sup>[4]</sup> Mukhtar Nadeem, <sup>[5]</sup> Harish A  
<sup>[1][2][3][4]</sup> Student, Department of Mechanical Engineering  
<sup>[5]</sup> Assistant. professor, department of Mechanical Engineering  
<sup>[1][2][3][4][5]</sup> BNMIT, Bengaluru, Karnataka, India

**Abstract:** -- The purpose of this article is to present an agro machine which was developed to perform operations such as seed sowing, fertilizer spreading and pesticide spraying. The first among the above mentioned operation is mechanically driven which consist of an intermittent metering mechanism to serve a primary purpose of achieving uniformity between the seeds to be sown. The other two operations is achieved by using a motor and submersible pump powered by a battery which in turn is recharged by a photovoltaic array. The performance of the machine is a measure of area covered uniformly and effectively. This machine is intended to reduce the efforts of the farmer by replacing the hand tool by mechanisms, the involvement of solar power as the primary source is even more convincing as it avoids use of conventional source of energy.

**Keywords:** Fertilizer Spreader, seed metering, pesticide spraying

## I. INTRODUCTION

Agriculture is the backbone of India. It plays a vital role in India's economy. Over 58% of the rural households depend on agriculture for their livelihood. Agriculture accounted for 15.35% of India's GDP in 2015-16. India stands second in farm output. About 95 million hectares of land is being used for cultivation. About 90% of farmers depend on non-renewable energy resources such as electricity, petroleum for their agricultural activities. Today's world faces energy crisis especially the rural background, to meet the future energy demands the use of nonconventional energy as an alternate solution is inescapable. In order to meet the food requirements of growing population modernization of agriculture has become necessary. However farmers have been mainly using traditional techniques like hand operated and fuel consuming machines or tools in the activities such as sowing of seeds, spraying of pesticides, dispersing fertilizers etc. Nowadays the concept and technology employing renewable energy has become very popular, with this motivation we are intended to improvise on the following three operations, namely

- Seed sowing
- Spraying of pesticide
- Spreading of fertilizer

### A. Background:

This section highlights the present state of agricultural farm machinery and equipment pertaining to the above mentioned operations.

### 1) Seed sowing

In planting wider rows generally 75 cm or more, the intent is to have precise even spacing between the individual seeds in the row. Various seed metering mechanisms have been devised to count out individual seeds at exact intervals.



*Fig.1 Manual Seed Sowing*

### 2) Fertilizer spreading

A fertilizer is any material of natural or synthetic origin that is applied to soils or to plant tissues to supply one or more plant nutrients essential to the growth of plants. Fertilizers are commonly used for crops, with application rates depending on the soil fertility and type of crop. Various mechanisms have been incorporated for uniform spreading of fertilizer.



*Fig.2 Conventional fertilizing*

### 3) Pesticide Spraying



*Fig.3 Conventional Pesticide spraying*

The pest population has to be kept suppressed to minimize biological activities to avoid economic loss of crop yields. Proper technique of application of pesticide and the equipment used for applying pesticide are vital to the success of pest control operations.

## II. LITERATURE REVIEW

M.V.Achutha et al [1] studied the factors that influence the performance of a agro machine which performs operations such as sowing, fertilizing, spraying and intercultivation. Based on this study a plug matrix selection criteria was used to select best among the concepts developed by them, the primary reason to reject other concepts was that it had mechanisms like chain-sprocket, gears etc. which would increase the complexity in manufacturing .

The concept that was selected had a single frame used to mount all the equipments like chemical sprayer at the front of the wheel, a cylinder to store the liquid, a hopper placed near the operator to monitor the seed and fertilizer flow rate.

Nithin PV et, al [2] designed a robot which can dig the soil, sow the seeds, levels the soil and sprays the water, the robot works on solar power. The vehicle movement is controlled by relay switch through an IR sensor. One end of the frame consists of cultivator which is driven by DC motor which is used to dig the soil. Sowing unit consists of hopper and as haft with hole. A DC pump is used to spray the water.

Kyada A.R and Patel D.B. [3] developed a manually operated seed planter machine to improve planting efficiency for different size of seeds at desired depth and uniform spacing. To gain adaptability for various crops four mechanisms were used. A seed metering mechanism which consists of circular plate with peripheral slots to collect the seeds intermittently. Plunger is used whose depth of penetration is cam controlled. Power transmission system consists of a gear sprocket which is used to get uniform spacing for different crops. Pulling mechanism is used to keep plunger stationery while it is inserted in to the soil and brings it to original position while plunger comes out from soil.

Narode R.R et al [4] developed a method to spread the fertilizer uniformly over a fallow land by dropping the fertilizer over the impeller disc. The system consists of a three wheels, two at the front and one at the back. These two wheels at the front are used to impel the fertilizer. The two hoppers are used to store the fertilizer, these hoppers are placed at some height from the wheel axle so that the fertilizer falls on to the impeller. The hopper is provided with flow controller using a Spring Mechanism. In normal conditions spring is not in tension and hopper is closed. As operator apply tension on the spring, the control plate moves backward and hopper gets opened, below which there is an impeller which spreads fertilizer.

Rajesh et,al [5]studied the materials of solar cell which effect the overall efficiency and discussed about the trends to harvest solar energy and they developed a solar pesticide sprayer which is beneficial in terms of cost of spraying , less vibration, saving of fuel etc. over fuel engine pesticide sprayer.

### III. METHODOLOGY

With the demand for better farm outputs, the aim was to fabricate affordable multipurpose agro machine without sacrificing its performance for increasing the economy of small scale farmers. For fulfilling this aim it is decided to follow following steps:

- Review various literatures pertaining to the multipurpose agro machine.
- Model and fabricate the machine as per the requirements and standards.

#### A) Archival reports

The information pertaining to the requirements and expectations of the farmers in an agro Machine and also best alternatives for component procurement, manufacturing etc. was studied through various journals. The following conclusions were drawn

- [1]The agro machine must be user friendly capable to suit the farm land requirement
- [2]The agro machine must be able to sustain variable loads
- [3]Auxiliary mountings such as solar panel, battery etc. must be cost effective and also easily available
- [4]The agro machine must be a effective replacement for traditional methods

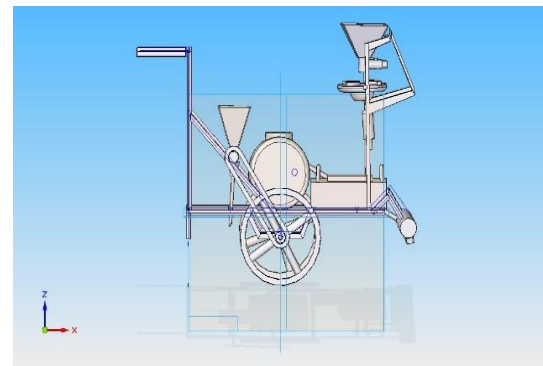
#### B) Modelling the agro machine.

The data that were obtained from various research papers and commercially available models are used to finalize the specifications of agro machine on basis of information collected from farmers, retailers and various journals the following objectives were set

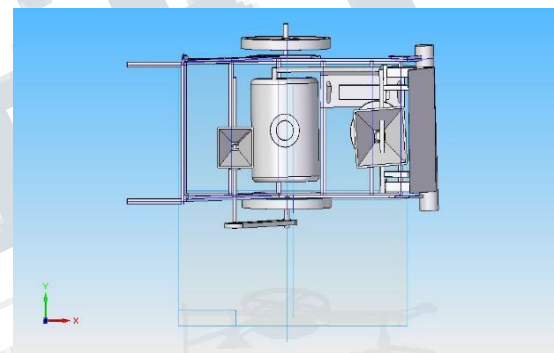
- Developing and Fabricating a compact machine
- Decrease the cost of machine
- Decrease the labour requirement for fertilizer spreading, seed sowing and spraying
- Using proper metering mechanism to increase the efficiency of seed spacing

So considering these points related to above mentioned operations an attempt is made to develop, fabricate and

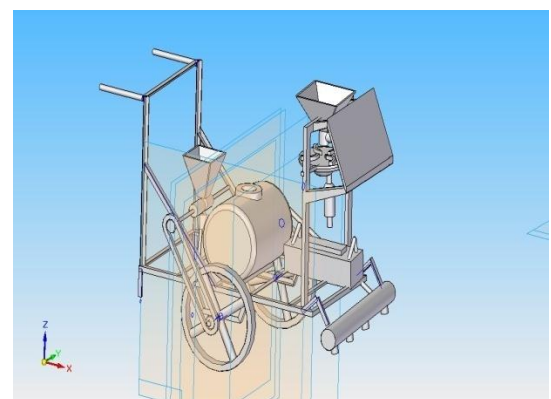
validate such equipment which will be able to perform the operations more efficiently with less procurement and manufacturing cost.



**Fig.4 Right side view of Agro machine**



**Fig.5 Top view of Agro machine**



**Fig.6 CAD model of agro machine**



#### IV. WORKING

The machine performs three operations namely 'Fertilizer spreading, Pesticide spraying and Seed metering'. The first two operations are solar powered and the last operation is ground wheel driven. It is a walk behind type of multipurpose agro machine which consists of a 20W solar panel used to charge a 12Ah battery which powers a 2W DC motor and a 4W submersible DC pump. The required speed of the spreader vane to impel the fertilizer should not be less than 500 rpm to cover an area of 12m<sup>2</sup> so a motor of 2W capacity is used. The estimated discharge through a nozzle was found to be 0.9ltr/min, taking into account the presence of 4 nozzles and pressure drop in the pipe connecting the tank we choose a submersible pump of 5l/min discharge. Two truncated cylinders with slot between them enables intermittency in seed dropping from hopper. A housing is used to guide the metered seed on to the soil.

#### A. DETAILED DESCRIPTION OF PARTS

##### 1) Main Frame

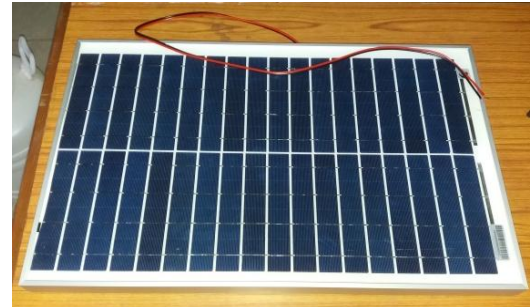


*Fig.7 Mai Main frame*

The frame of multipurpose agro machine with dimension 550X750X700 (l X b X h)mm<sup>3</sup> employs a ladder type of chassis to account for variable load of the pesticide tank. The mild steel angle section is used to fabricate the frame which is light and strong enough to be used in farm lands.

##### 2) Photo voltaic array

Considering factors such as battery capacity charging time size of frame etc., a 20W of flat plate collector type solar panel with dimensions of 550 X 350 (l X b) mm<sup>2</sup> is procured and installed.



*Fig.8 Solar Panel*

##### 3) Battery and charge controller



*Fig.9 battery and charge controller*

Based on the net load of pump and motor together and operating time a lead acid battery of capacity 12W , 12Ah is used to prevent over charging of battery a charge controller is used .

##### 4) Fertilizer spreader

A vane of diameter 50mm which is mounted on to the motor impels the continuous flow of fertilizer from the hopper. Speed of motor is 500rpm and it is powered by the 12Ah battery.



*Fig.10 Fertilizer spreader*

**5) Pesticide sprayer**

The desired discharge from a sprayer is found to be 0.9l/min, four such sprayers makes the net discharge to be 3.6l/min taking into account the pressure drop in the pipe connecting the pump and sprayer a discharge of 5l/min is found mandatory. A 4w submersible pump with a discharge of 5l/min is installed inside the pesticide tank.



Fig.11 Pesticide sprayer

**6) Seed metering**



Fig.12 Seed metering assembly

The primary purpose of seed metering mechanism is to obtain uniform spacing between two seeds for which an intermittency in seed fall is require, this is achieved by using a mechanism which consist of two truncated cylinders with a space between them. Both of the cylinders are driven by a common square shaft. The shaft is powered by the ground wheel through chain-sprocket mechanism .the seeds are fed into this mechanism by a hopper at the top. The square shaft is supported by bearings to avoid unwanted vibration and for smooth functioning. A housing

is provided to ensure that the seed are not dispersed haphazardly.

**7) Chain sprocket assembly**

Two sprockets having 18 and 42 teeth are connected by a chain. The bigger sprocket is mounted on the wheel and the small sprocket is mounted on the rectangular shaft.



Fig. 13 chain-sprocket

**8) Wheel sprocket assembly**

The bigger sprocket ie 48 teathed sprocket is mounted on the wheel by fastening by a 12mm bolt .



Fig.14 wheel sprocket

**7) Final Assembly**

All the components are brought together and then mounted on the frame. A 20ltr pesticide tank consisting of submersible pump is fastened on the base of the frame. The carriage consisting of fertilizer spreader and solar panel is mounted on frame to certain height. The discharge pipe consisting of sprayers lies on front of machine. The battery and charge controller are placed adjacent to tank. Seed

metering mechanism along with bearings are bolted on the rare side of the machine. Shaft of seed metering mechanism is chained to ground wheel through sprockets.



*Fig.15 final assembly of developed Agro machine*

## V. CALCULATIONS

### A) Specifications

Desired discharge from each Nozzle=0.9lit/min

Number of nozzle=4

Net discharge =3.6litre/min

*Pump specifications to meet the above requirements*

Power=4watt

Discharge=5litre/min

*Motor specifications*

Power =2watt

Speed=500rpm

Torque=3kgf

*Battery specifications*

Net DC load =6W

Required battery backup time = 2 hrs.

Power =12Ah

*Selection of solar panel*

Current = 1.2 A

Power= 20W

### A) Actual cost of the machine

Sl No	Material	Specification	Quantity	Cost (Rs)
1	Solar panel	12 v, 20w	1	1850
2	Battery	12 v, 12 Ah	1	1800
3	Chare controller	12 v, 2A	1	650
4	DC pump	12 v,60 w	1	1460
5	DC motor	200 rpm	1	125
6	Flat steel strips	5 m	1	250
7	Angle steel strips	5.5m	1	350
8	Castor wheel	20 cm dia	2	700
9	Sprocket	41 T,18T	2	250
10	Chain	1.5m	1	150
11	Nozzles	0.7 L/min	4	200
12	Impeller Disc	15 cm dia	1	125
13	Hoppers	2 kg	2	500
14	Pesticide tank	20 Ltr	1	210
				<b>Total= 8620</b>

*Table 1*

## VI. RESULTS

### A) Comparisons of the developed model with traditional methods

Specification	Agro machine	Traditional
Energy Sourcing	Solar	Manual
Number of nozzles	4	1
Pesticide tank capacity (litre)	20	15
Net	3.6	1.2



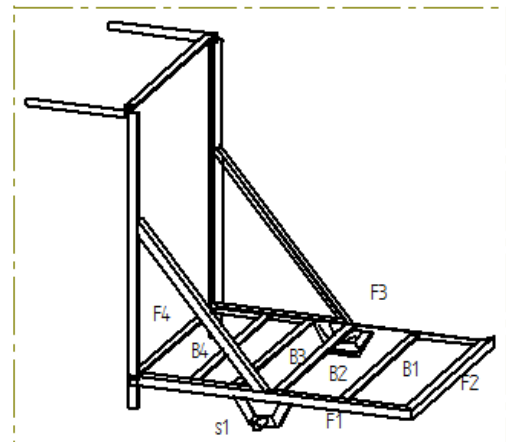
Discharge(liter/min)		
Swath width(mm)	1300	500
Time taken by the sprayer for one acre of land in hours	1to1.5	5
Area covered by the Spreader(m <sup>2</sup> )	12.5	6
Time taken by the spreader to cover one acre in hours	1	2
Model cost	5000	3600
Labour cost	500	800x5=4000
Total cost of the sprayer	5500	7600
Seed ,metering mechanism and its auxiliary	2000	-
Labour cost		500x4
Model cost	1000	-
Labour cost	150	500x4
Total cost of the spreader	1050	2000
Frame	1500	-
Model cost	9500	3600
Labour cost	650	8000
Total cost of seed metering mechanism	10,050	11,000

**Table 2**

The proposed model is fabricated and is able to perform the desired operations. The developed seed sowing mechanism is capable of sowing the seeds intermittently. The number of seeds sown is found to be 2 to 3seeds/revolution. However uniform seed spacing is achieved and it is found to be 380mm.The mechanism is able to avoid unwanted dispersal of seeds

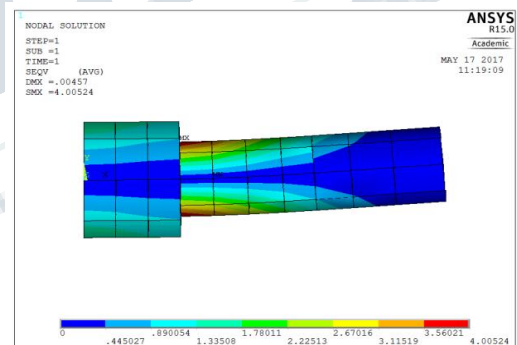
**B) Analysis of critical members of frame**

Based on the loading, cross sections and symmetry of machine the following members were found critical, stress analysis was done to ensure them safe.

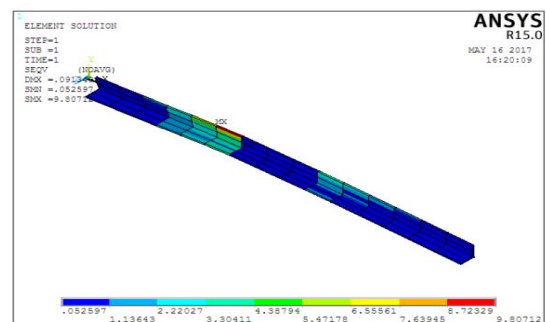


**Fig.16 Frame of the Agro Machine**

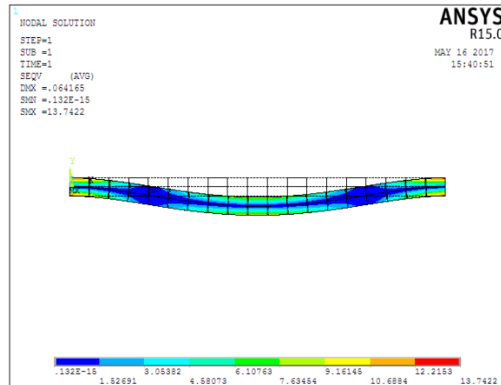
The Critical members in the above depicted figure is F1, F3, S1, S2, B2 and B3. But the Symmetry in the frame allows us to restrict ourselves to members such as F1, B2 and S1.



**Fig.17 stress analysis of wheel shaft S1**



**Fig.18. Stress analysis of member F1**



**Fig19. Stress analysis of members B2 and B3**

The members are modelled and analysed using ANSYS and it is found to be safe using maximum distortion energy theory (Von mises). The factor of safety of Developed Agro machine is found to be 14

### VII. SCOPE FOR IMPROVEMENT

- The land needs to be prepared before employing seed sowing mechanism so a tiller can be incorporated in the machine for ploughing the land
- Modification in hopper design, vanes and nozzles can be done to obtain uniform flow rate of seeds and area covered.
- By increasing the diameter of the wheels and capacity of the panel we can increase the area covered by the spreader and vehicle can run automatically.

### VIII. CONCLUSION

After comparing various models the agro machine has considerable potential to increase productivity and decrease the labour effort, cost and time. It is effective replacement for usual labour in medium and small scale farm lands. The cost for various components is less expensive and are easily available compared to other existing models by using this machine there is flexibility in area covered and time taken. The model is designed to be eco-friendly and less maintenance, operating cost and thus

it is proved to be more efficient when compared to petrol based pesticide sprayer.

### REFERENCES

- [1]MV Achutha, Sharath Chandra N, Natraj (NIE Mysore) concept design and analysis of multipurpose farm equipment [issue 2, volume 3, Feb 2015]
- [2]Sridhar R, Syed Moinudeen, Sanjay (JNNIE Chennai) design and fabrication of mechanical pest sprayer [issue 10, volume 4, Aug 2015]
- [3] VM Martin Vimal, A Madesh, S Karthik (CVSCE Coimbatore) design and fabrication of multipurpose sowing machine [issue 5, volume1, Aug 2015]
- [4]Narde R R, Sonawane A B, Mahale R R (university of Pune) manually operated fertilizer spreader [issue 2, volume 5, Feb 2015]
- [5]Rajesh R, Vimal Kingsley, M Selvapandit, Niranjan (Dhanalakshmisrinivasan college of Engineering) Design and fabrication of solar pesticide sprayer [issue 8, volume 5, May 2016]
- [6]Elements of Strength of Materials 5e S.P.Timoshenko / D.H.Young
- [7]Transforming Agriculture Through Mechanisation, A Knowledge Paper on Indian farm equipment sector FICCI