

Design Analysis, Implementation and Experimentation of a Force Base Torque Sensor for Aerospace Applications

- ^[1] Dr. T.C.Manjunath, ^[2] Pavithra G, ^[3] Satvik M. Kusagur ^[4] Dr. Nagaraj B.G ^[5] Dr. Arunkumar G
^[1] Ph.D. (IIT Bombay), FIETE, FIE, CE, SMIEEE, Professor & HOD, ECE Dept., Dayananda Sagar College of Engg., Bangalore
^[2] B.E., M.Tech., [Ph.D.-VTU-Pursuing] Research Scholar, VTU – RRC, Belagavi, Karnataka
^[3] B.E., M.Tech. [Ph.D.-VTU-Pursuing] Visiting Faculty, Jain Inst. of Tech., Davanagere, Karnataka & Full Time Research Scholar, VTU – RRC, Belagavi, Karnataka
^[4]B.E., M.Tech., Ph.D. Prof. & HOD, ECE Dept., Jain Inst. of Tech., Davanagere
^[5]B.E., M.Tech, Ph.D. Faculty, Department of Electronics, IBRI, OMAN

Abstract:-- This research paper deals with the design, development and implementation of a force - torque sensor interface (instrumentation) based on the Stewart Platform structure. It also involves recreating the applied force at a desired location. A brief kinematic design of the sensor interface is being carried out. The geometric form of the sensing elements and the synthesis of the leg is also presented. The force torque sensor is interfaced to the internet using the TCP / IP protocol also, instrumentation amplifiers, ACD's, etc..

I. INTRODUCTION

The Stewart platform structure consists of two plates and six connectors or legs. The top plate is termed as the platform and the bottom plate is known as the base. The legs are the sensing elements of the sensor. The transducer element used is the Strain Gauge. The strain gauges are mounted on each leg. The wrench is applied to the top plate.

The wrench is a 6 dimensional vector and consists of 3 component forces and 3 component moments. The legs are so positioned that the applied force gets distributed into the six leg forces. Consequently each of the leg of the sensor experiences some strain. This strain is sensed by the strain gauges on the leg and they generate a corresponding electrical voltage. In this manner the six leg forces are obtained.

The six leg forces obtained are not the actual forces. These leg forces have to be properly resolved to generate the three forces F_x , F_y , F_z , along the x, y, z direction and the three moments M_x , M_y , M_z about the x, y, z direction. The three forces and the moments are obtained from the leg forces using the force transformation matrix also called as the Jacobean matrix. It is denoted by $J(q)$ as

$$J(q) = \begin{bmatrix} C_{11} & C_{12} & \dots & C_{16} \\ \dots & \dots & \dots & \dots \\ C_{61} & C_{62} & \dots & C_{66} \end{bmatrix} \quad (1)$$

The Jacobean Matrix $J(q)$ is invariant during the sensor operation. Only during calibration, the Jacobean matrix elements are tuned to effect corrections. The matrix elements of the Jacobean matrix are listed below.

$$\begin{bmatrix} -0.179 & -0.378 & 0.258 & 0.205 & -0.079 & 0.173 \\ -0.195 & -0.018 & -0.058 & -0.318 & 0.253 & 0.337 \\ -0.964 & -0.926 & -0.964 & -0.926 & -0.964 & -0.929 \\ 0.000 & -2.746 & -2.505 & 1.013 & 2.505 & 1.723 \\ 2.893 & 0.415 & -1.446 & -2.585 & -1.446 & 2.170 \\ -0.585 & 1.113 & -0.585 & 1.113 & -0.585 & 1.113 \end{bmatrix} \quad (2)$$

II. INTRODUCTION

The analog signals undergo signal conditioning in order to increase their signal to noise ratio (SNR). The analog signals have a very low voltage level. An instrumentation Amplifier is used to amplify them to the desired level. The instrumentation amplifier designed and used here is IC-INA 110. The choice of the instrumentation amplifier is done on the basis of the Common Mode Rejection Ratio, Low gain temperature coefficient; log gain error, low offset and low noise. The data obtained from the instrumentation amplifier is in the analog form. Since the computer is the digital device the conversion of

the data is essential.

At the client side the analog voltages are retrieved from the digital data using DAC. The DAC converted the digital data back into the analog form and thus the force applied also called as the wrench was recreated back. The above system is used to communicate force to remote place. The force given at the sensor side for the communication from the sensor is recreated back at the client side.

The recreated force can be used to drive motor or any other devices. Normally, such sensors are used in Nuclear Reactors where human beings cannot work. The system is implemented by conventional electronics. The need to embed the electronics and the associated software is to make the sensing system alone very compact.

The sensing system is integrated to the robotic system or acts as a standalone system at remote or hazardous places. The Figure below shows the individual blocks of the designed and implemented sensing and force communicating system. The wrench is a 6 dimensional vector consisting of 3 component forces and 3 component moments. TCP/IP is the

Transmission Control Protocol and the Internet Protocol. The 6 axis force torque sensor is used to embed the electronics and the associated software to the sensing system alone very compact. The sensing system is integrated to the robotic system or acts as stand alone system at remote or hazardous places. The Fig. shows the individual blocks of the designed and implemented sensing and force communication system.

III. BLOCK DIAGRAM EXPLANATION : INSTRUMENT

The basic instrument used for the conversion of the force from one parameter to another is the Stewart Platform. The Stewart platform is a 6 DOF parallel mechanism by Stewart. The form of mechanism is reciprocal to that of a serial mechanism and hence properties of the Stewart Platform are also quite reciprocal to that of serial mechanism. It has a high load capacity since its in-parallel linkages sustain the payload in distributive manner.

Its other characteristic is high positional accuracy, which results from the fact that the joint errors are not cumulative as in serial manipulators. The aspect of

compact design with 6 DOF along with the above-mentioned properties prompts one to consider the mechanism for force-sensor.

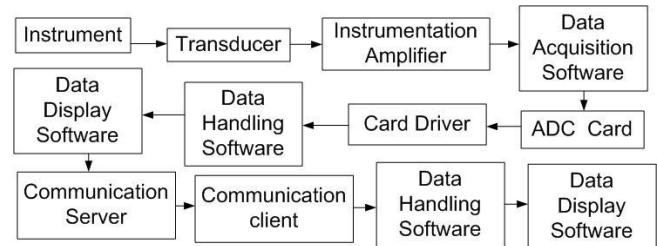

Fig. 1 Block diagram of the designed system

IV. KINEMATIC SYNTHESIS

A semi-regular hexagonal arrangement of connection points on a plate is considered for the base and for the platform. The angles made by alternate segment of the hexagonal at the center are equal. The force and torque experienced by the Stewart Platform are distributed to the 6 legs connecting the top and the base plates. The measurement of the deformations of the legs enables us to determine the external force and torque through force transformation matrix.

The kinematic design of force-torque sensor presented here is a stiff sensor in the sense that the deformations of the legs are insignificant from the positioning point of view. The kinematic design of the Stewart platform is carried out by minimizing a condition number of the transformation matrix which relates the applied forces (platform wrench) and measured forces (leg forces)

V. GEOMETRICAL FORMS OF THE SENSING ELEMENTS AND SYNTHESIS OF THE LEG

The crucial element as far as instrumentation is concerned is the leg : a part that connects the base plate and the top plate and there are six of them. The form of the leg has no kinematic consequence and hence the condition number is independent of the geometric form of the leg. The choice of the form of the leg is made to enhance the performance of the sensor in terms of sensitivity, accuracy, repeatability and ease with which strain gauges can be mounted.

The form of the leg is obtained by minimizing force to strain ratio i.e., maximizing SNR subjected to

design constraints such that the strains are within the elastic limit for the given maximum wrench and also to facilitate mounting of strain gauges on legs. Ring shaped legs seem to be more promising and closely fit the requirement of the application. They have higher strain level in the gauge area at rated load thus increasing the sensitivity of the system.

They develop uniform strain distribution in the strain gauge area. The maximum allowable strain level in gauge region limits the output of the gauge. The strain level exists uniformly over the entire area of the gauge grid to maximize the signal. The ring element can be machined from a single piece. Monolithic, construction can be utilized to give lower strain level throughout the remainder of the elastic element to ensure better fatigue life, linearity, and freedom from creep and hysteresis, thus considerably reducing the emergence of spurious signals.

The ring type elastic elements provide minimum thermal impedance between strain gauges in adjacent arms of the same bridge circuit and enables the temperature effect to be compensated automatically resulting in good quality bridge output. Also for a given axial force the characteristics of bending give rise to stresses of opposite sign on opposite faces of measurement resulting in amplification of the signal by two folds. Further enhancement of SNR can be considered by compressing the circular ring form to elliptical form.

The elliptical form retains all the advantaged of ring type element and at the same time gives further scope to size the Stewart platform optimally.

VI. INSTRUMENTATION AND INTERFACE

Bonded metallic resistance strain gauge has been used to mount on the legs. Since the gauge responds to surface strain in a structure, the legs acting as elastic structures must be carefully designed as a transducers which must give proper resisting and restoring characteristics when load is applied and withdrawn.

The block diagram shown in Fig. 1 gives interface details of the sensor. Software has been developed to self calibrate the sensing system and to regulate the sensor. Each time when the software is executed, it keeps the system under wait state until all the strain gauges reach the stable initial value. This is done to ensure against reading any spurious channel values built up during warming up period.

The initial channel values are then set to zero to read the initial reference load to zero. It is found that it requires less than 1 ms in a PC-386 operating at 33 MHz to read channel values and perform a matrix multiplication to compute the force vector. The 6 analog voltage signals obtained from the signal conditioning and instrumentation amplifier stage correspond to the leg forces.

These analog signals need to be processed in order to compute the force vector and for the display and transmission purposes. ADC is used to achieve this. The conversion of the analog data to the digital form is done using the software. The designed software controls the data flow and the display.

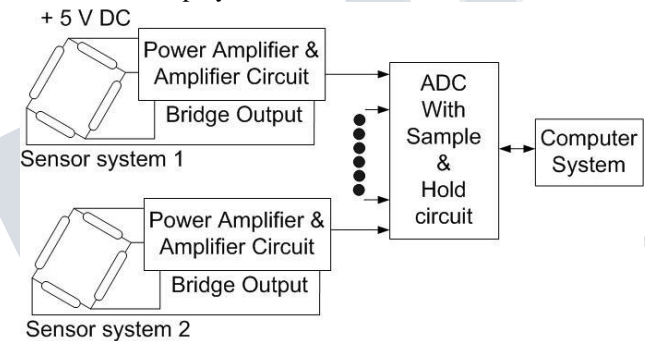

Fig. 2 Interface details of the sensing system

The transducer, converts the non-electrical signal into a proportional electrical signal as the analog signal have a very low voltage level. So the instrumentation amplifier is used to amplify the signal. There are 4 sensing strain gauges on each component of a 6-component sensor. For a particular force, the outer surfaces of the sensing element would be in tension and the inner surfaces in compression.

Therefore, the strain experienced by the outer and the inner surfaces are of different sign. Metallic foil strain gauges are used for both inner and outer surfaces. They are connected in 4 element bridge configuration as shown in the Fig.2. Each bridge is excited by a stable 5 V power supply.

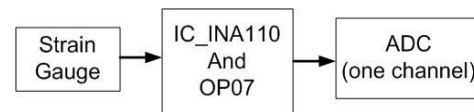

Fig. 3 Bridge excitation

The output of the bridge is fed to the input of the instrumentation amplifier IC_INA110. The choice

of INA110 is because of its high common mode rejection (90 DZ), low gain temperature coefficient (25 ppm /deg C), log gain error (0.05 % at G = 500), low offset and low noise. Each bridge has external stable metal film resistor for making null offset adjustment.

The amplifier circuit is designed to have an option of second stage amplification. The option can be set by jumper settings. The second stage amplifier is an operational amplifier OPAMP (OP 07) whose gain can be varied from 4 to 10. OP 07 has a very high CMRR (100 dB), low input off set (10 mV/deg C). The output is buffered by another OP 07 and brought to the input of the standard 12-bit ADC card.

The instrumentation amplifier in conventional form is been developed and implemented. It is a separate unit. The need to develop a dedicated, embedded instrumentation amplifier along with others is listed in the sensing section. The details of the conventional instrumentation amplifier is being used. The embedded system should have similar performance specifications. However, modifications and changes which might lead to simplification, economical add technically better system can be accommodated. Differential 8 Channel programmable amplifier and programmable filter and 0-10 volt programmable excitation source on each channel.

VII. ANALOG TO DIGITAL CONVERSION

The need for ADC is as follows. The 6 analog voltage signals obtained from the signal conditioning and instrumentation amplifier stage corresponds to the 6 leg forces. These analog signals need to be processed in order to compute the force vector for display and transmission purposes. By using A / D conversion, the analog voltages are correspondingly digitized. This digital information is easily processed by a PC. The ADC used is a PC Lab Card PCI-1713.

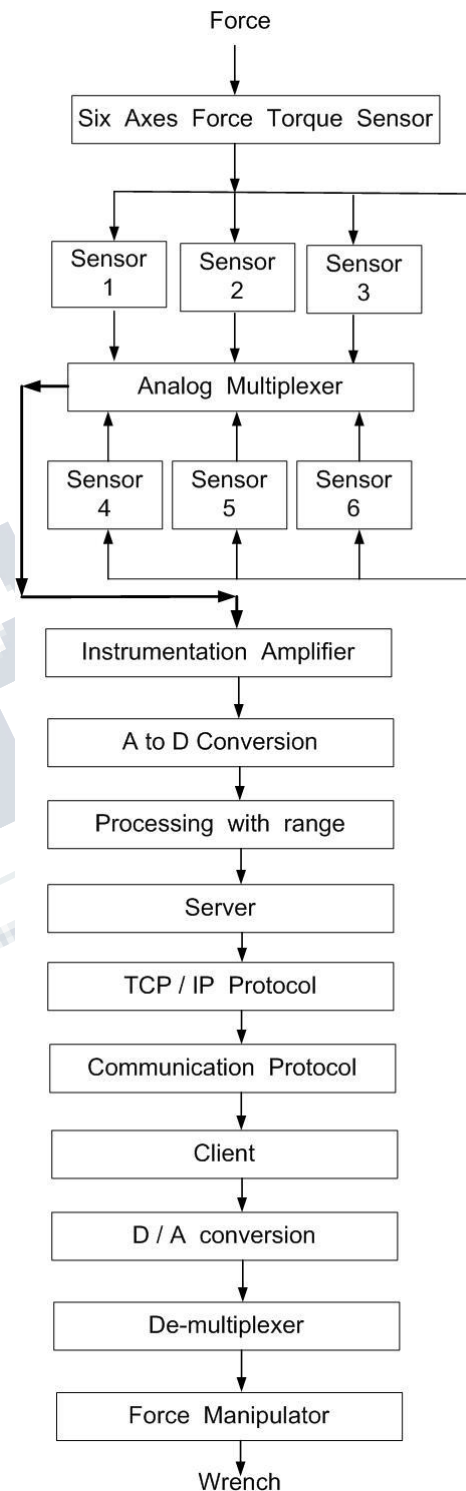

Fig. 4 Flow chart of the implemented software

VIII. SOFTWARE INTERFACING

The conversion of the analog data into the digital form is done using the designed software. The data flow and the display is too controlled by software. The flow chart algorithm is shown in Fig. 4.

IX. PROGRAM FOR THE COMMUNICATION

TCP / IP protocol is used for the internet / internet connection. The data is transmitted between 2 computers with server client server relationships. The server is linked with the A / D program. The force values obtained in terms of raw data, voltage, etc., are stored in the buffer in the server. The values are further processed and passed on to the client computer. At the client side, the values are processed and displayed on the screen.

X. PROGRAM FOR THE DISPLAY

The display of the data is required at both the server and the client. The display is done using multiple windows on the screen. The program takes the force values and displaces on the time graph. The continuous display of the data or the force value is obtained in the graphical form. The display is done in a number of ways. First method is the bar graph method. Also, continuous display of the values in the time variance form is done.

XI. COMPUTATION OF THE FORCE COMPONENTS

The 6 analog voltage values digitized by the card correspond to the 6 leg forces of the sensor. Since, our aim is to transmit the composite force vector, we need to compute the force and moment components with respect to the reference axis from the leg forces.

$$[F] = [M][f] \quad (3)$$

Where

$[F]$ is the composite force matrix,

$[M]$ is the force transformation matrix,

$[f]$ is the matrix comprising of the leg forces.

The maximum force the sensor can withstand is ± 60

Newtons. We are mapping ± 60 N to ± 5 V.

Hence,

$$[F] = \left(\frac{6}{5}\right)[M][v] \quad (4)$$

where,

$[v]$ is the set of voltage values corresponding to the leg forces that we obtain from the ADC card. The program displays the set of 6 analog voltages appearing at the card inputs and also the 3 force and 3 moment components corresponding to that set of analog values.

Applications

- ♣ Defense applications
- ♣ Robo surgeons
- ♣ Under sea explorations
- ♣ Nuclear explorations

Working of the designed system

The working of the 6 axis stiff force torque sensor is explained as follows.

- ♣ The force applied on the Stewart platform is sensed and converted into the electrical voltage, which is analog in nature.
- ♣ The analog force is then converted into the digital form.
- ♣ The digital data output of the ADC is then processed by the server computer and transmitted on the internet / intranet using the TCP / IP protocol.
- ♣ At the client side, the computer again processes the data and the feeds to the DAC.

XII. CONCLUSIONS

A electronic sensor interface for a Stewart platform was designed and implemented successfully.

REFERENCES

- [1] A. Romiti and Sorli, "Force and measurement on a robotic assembly hand".
- [2] M. Uchiyama and Hakamodi K, "A few considerations on structural design of force sensor".
- [3] **D. STEWARD, "A PLATFORM WITH SIX DEGREES OF FREEDOM FOR AEROSPACE ENGINEERING APPLICATIONS".**

