

# Vehicle Health Monitoring System Using CAN

<sup>[1]</sup> Mrs. Sheeladevi M, <sup>[2]</sup> Jeyadevan S, <sup>[3]</sup> P Udaysree, <sup>[4]</sup> Priyanka V J, <sup>[5]</sup> Ranjitha S, <sup>[6]</sup> Ranjitha V  
<sup>[1,2,3,4]</sup> UG Scholar, Sri Sairam College of Engineering, Bengaluru, India  
<sup>[5]</sup> Professor & HOD (CSE), Sri Sairam College of Engineering, Bengaluru, India

**Abstract**— Due to multiple connections of data & electrical lines connected to microcontroller it becomes very complex to understand & troubleshoot it. It also restricts us long distance data transfer due to large number of lines. To minimize all these problems, we can use “CAN” protocol to connect these entire network. CAN (control area network) enable us to connect all the devices together using only two wires. Due to this, the number of lines connected to microcontroller reduces greatly & circuitry becomes simple to understand & troubleshoot. Using CAN protocol we have connected multiple microcontrollers & other devices to a common can bus like light sensor, temperature & ultrasonic sensor.

**Keywords:** -CAN, PIC, PS, PCB, IC

## I. INTRODUCTION

Present Automobiles are being developed by more of electrical parts for efficient operation. In case of microcontrollers as we know it's a central controlling unit and all the other devices or circuitries connected to it. Due to multiple connections of data and electrical lines connected to microcontrollers, it becomes very complex to understand and troubleshoot it. This project presents the development and implementation of a digital driving system for a semi-autonomous vehicle to improve driver vehicle interface. The communication module use in this project is embedded networking by CAN which has efficient data transfer. Using CAN protocol we can connect multiple microcontroller and other devices to a common CAN bus. To connect it to CAN bus we require a CAN transceiver in between bus and devices which enables the communication between all thing with great speed and priority.

This project also presents the development of distance measurement using ultrasonic sensors which denotes the vehicle's position from obstacles. It is important that human drivers still have some control over the vehicle. This project is aimed at the implementation of CAN protocol using PIC for ehicle monitoring system. The main feature of the system includes monitoring of various vehicle parameters such as Temperature, presence of CO level in the exhaust, Battery Voltage and Light due to spark or fire. The software part is done in Mikro C using embedded C.

## II. RELATED WORKS

### A. Existing System

Fig.1 Block Diagram Of Existing System(Without CAN)  
 To improve the working of vehicle further, it is necessary to control overall system to exchange information. In existing system this is done using discrete interconnections of different systems means by using point to point wiring. For

information exchange up to several miles length of cable network becomes very large and it increases connectors. This produces growing problems along with material cost, production time.

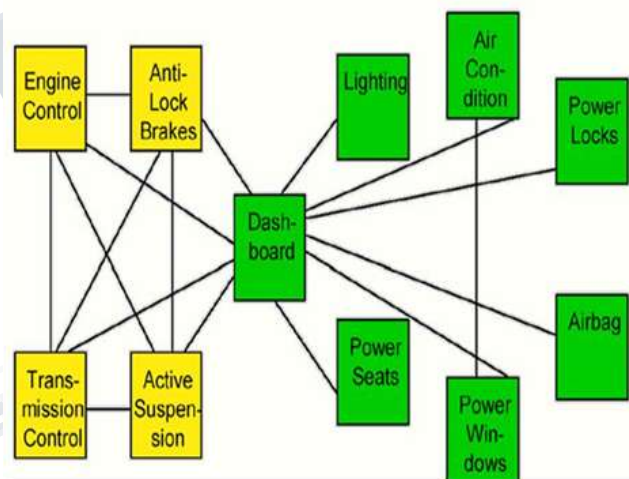

### B. Need of CAN

- CAN is mature standard
- CAN protocol more than 16 years
- Numerous CAN products and tools on the object
- Hardware implementation of the protocol
- CAN Bus used for the combination of error handling and fault confinement wit high transmissionspeed(up to 1Mbps)
- Simple transmission medium
- Twisted pair of is the standard, but also just one wire will work
- Other links works, too: Opto – or radio links
- Excellent error handling
- Fault confinement
- High speed, real time communication
- Provide noise immunity in an electrically noisy environment

**III. PROPOSED SYSTEM**

**A. After CAN**

The solution to this problem was the connection of the control system via a serial bus system. This bus had to fulfill some special requirements due to its usage in vehicle. With a use of CAN, point to point wiring is replaced by one serial bus connecting all control systems. This is accomplish by adding some CAN specific hardware to each control unit that provides the “rules” or the protocol for transmitting and receiving information via the bus.

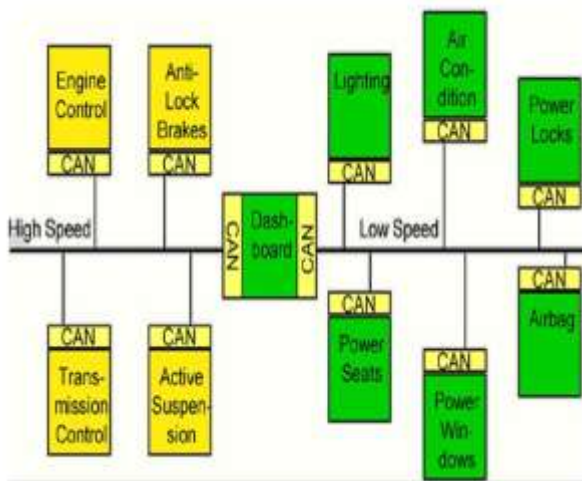

**Fig 2. Block Diagram Of Proposed System (With CAN)**

**IV. TECHNIQUES USED**

**A. Ultrasonic Sensor**

Ultrasonic sensors (also known as transceivers when they both send and receive, but more generally called transducers) work on a principle similar to radar or sonar which evaluate attributes of a target by interpreting the echoes from radio or sound waves respectively. Ultrasonic sensors generate high frequency sound waves and evaluate the echo which is received back by the sensor. Sensors calculate the time interval between sending the signal and receiving the echo to determine the distance to an object. The sensor used in our project is HC-SR04.

**B. Temperature Sensor (LM-35)**

LM-35 was Calibrated Directly in ° Celsius (Centigrade). It is Linear + 10 mV/°C Scale Factor 0.5°C Ensured Accuracy (at +25°C) .Rated for Full -55°C to +150°C Range. LM-35 is Suitable for Remote Applications. It is Low Cost Due to Wafer-Level Trimming. It Operates from 4 to 30 V and Less than 60-µA Current Drain .It has Low Self-Heating 0.08°C in Still Air. And Low Impedance

Output, 0.1 Ω for 1mA Load. It indicates the low level and high level temperature measurement and automotive ignition level gas exhausting, over heat when vehicle engine/motor speed was increased gradually.

**C. Light Sensor**

A light sensor generates an output signal indicating the intensity of light by measuring the radiant energy that exists in a very narrow range of frequencies basically called “light”, and which ranges in frequency from infrared to “Visible” up to “Ultraviolet” light spectrum .Light sensors are more commonly known as “Photoelectric devices”. To accomplish our project ,we are using BC547 as a light sensing device.

**V. COMPARISON OF CAN PROTOCOL WITH OTHER PROTOCOL**

Parameters	CAN	RS232	SPI	I <sup>2</sup> C
Async /Sync	Async	Async	Sync	Sync
Type	Multi-Master	Peer-to-peer	Multi-Master	Multi-Master
Communication (Duplex)	Half	Full	Full	Half
Max Devices	112	2	Based on Bus Capacitance and bit rate	Based on bus capacitance and bit rate
Max speed	1Mbps	20 Kbps	>1Mbps	3.4 Mbps

**A. ADVANTAGES**

1. Reliability :- differential signaling
2. Priority:-easily prioritize messages
3. Low wire count
4. Node independence
5. can add / remove nodes
6. node breakdown doesn't bring down network

**B. APPLICATION**

- Most common use is in the automobile industry
- Used to connect subsystems within an electronic control unit as well as connect electronic control units together
- Many devices in cars use CAN including the radio, transmission, airbags, ABS, cruise control, and power steering
- CAN is also used in both railway and aerospace applications.
- Other applications include use in hospital equipment, elevators, and even coffee machines.

- [7]. Li.M .Design of embedded remote temperature monitoring system based on advanced RISC machine. Electronics Electric 06,p273.
- [8]. Prodanov.W.M. Valle &R.Buzas. A Control Area Network bus transceiver behavioral model for network design & simulation IEEE. Transaction on Industrial Electronics, 56(9):p3762-3722,2009.

**VI. CONCLUSION**

Instead of using multiple wires we used only two wired CAN protocol. Requirement of wires and also complexity reduced. Avoid accidents by monitoring different parameters as like distance or intensity of light and temperature.

**A. Future Scope**

- In Hospitals we can use CAN to manage complete operating system
- Home Automation
- Actuator application such as switches
- For security purpose

**REFERENCES**

- [1]. "OEM DD Minipod Fuel Tracking Technology".
- [2]. B. Gmbh, "CAN specification" vol 1 Version 2.0 1991.
- [3]. Pazul , "Control Area Network(CAN)Basics",
- [4]. Microchip Technology Inc., AN713,May 1999.
- [5]. Kumar M.A. Verma and A.Srividya, Response time modeling of Control Area Network(CAN). Distributed computing and networking. Lecture Notes in computer science Volume 5408,P163-174,2009.
- [6]. Tindell, K.A.Burns, and A.J.Wellings, calculating Control Area Network(CAN) message response times. Control Engineering Practice,3(8) :p,1163-1169,2005.