

# Smart Bus

<sup>[1]</sup>Bindhu.R <sup>[2]</sup>Hema.R <sup>[3]</sup>T.K Pradeep Kumar <sup>[4]</sup>Lorate Shiny

<sup>[1][2]</sup>UG scholars, <sup>[3][4]</sup>Assistant Professor

<sup>[1]-[4]</sup>Department of Computer Science and Engineering, Sri Sairam College of Engineering, Bengaluru.

**Abstract**— This is an automated system which will be fitted in the Bus for cleaning the dust particle from environment. The proposed technique is intended to facilitate the user to clean the dust particle through vacuum cleaner. In this system Microcontroller is the main unit, which controls the whole process. We are going to use AVR family microcontroller (ATMEGA 8/ ATMEGA 16). Vacuum Cleaner is used for cleaning the dust particle from road, which is connected with microcontroller. There is a container for containing the dust particle. We are going to use IR sensor for detecting the quantity of dust particle in container. IR sensor will be fitted on the top of container. When the container will be filled with dust container, then the sensor will detect it and send information to microcontroller. The sensor will be connected with Microcontroller. There will be one alert system for giving alert when the sensor will detect the quantity of dust. There will be one manual switch, which will be used for opening and closing of the container. Motors will be fitted on the top of container for opening and closing container. solar panels are placed on roof of the bus for power supply

**Keywords**:- Manual Switch. Microcontroller. Container.

## I. INTRODUCTION

The proposal aims at designing a unique system which can be controlled automatically for cleaning dust particles from road by using microcontroller. The Vacuum cleaner and sensors. This proposal use to automatically clean of dust particle from road public means, where vacuum cleaner is present for sucking the dust particle from road and store it on a container. When Container will be filled, then the system will give alert. There will be one switch on the system for opening and closing the container. The system is automated process, which is controlled by microcontroller unit. Sensors are used for detecting and vacuum cleaner is used for sucking the dust particle. The proposed technique is intended to facilitate the user to clean the dust particle through vacuum cleaner. We are using AVR family microcontroller (ATMEGA8/ATMEGA16), which controls the whole unit. To detect the quantity of container the IR sensor plays a major role. IR sensor is connected to microcontroller in order to send the alert signal Motor is fixed on the side of the container which helps it to open and close. Vacuum cleaner is an existing product.

## II. LITERATURE SURVEY

According to the survey of 2015-2016, the number of peoples travelling in public means is around 50 lakh in Bengaluru city. For instance ,BMTC busses not only serves as public transport, but also provides its

exclusive services to other organizations like IT companies ,Educational institutions, IT Tech parks, etc. Hence high percentage of people are dependent on BMTC.

## III. EXISTING SYSTEM

### 1. Vacuum Cleaner.

A vacuum cleaner, also known as a sweeper, is a device that uses an air pump (a centrifugal fan in all but some of the very oldest models), to create a partial vacuum to suck up dust and dirt, usually from floors, and from other surfaces such as upholstery and draperies.

### 2. GPS tracking system.

A GPS tracking unit is a device, normally carried by a moving vehicle or person, that uses the Global Positioning System to determine and track its precise location. There are two types of GPS tracker system, car tracking system the data pullers and data pushers. The way these things operate are different but the end result is similar, you come to know where your car had been and where did it stop for how long, what direction it took and how fast it drove, all the data from these car tracking system in India, GPS tracker systems in India like Delhi, Mumbai, Jaipur, Chennai, Bangalore and many more.

**IV. PROPOSED SYSTEM**

The system is designed for four wheeled Vehicles. The system is Fixed – Adjacent to the energy storage system. For power consumption we use solar battery. IR sensor is fitted on top of the container which senses and give signal to driver. The driver will dump the garbage in particular area. By this process we can keep the city roads clean. So 30% of our city can be kept clean. Even in rainy season ,the sensor fixed in the container detects the wet particles. It sucks the both dry and wet particles. Using the kinetic energy produced by the vehicles energy can be generated and used for vacuum cleaner instead of using stored energy .

dust particles from road sides and store it on a container. When container is filled, then the system will give alert signal to driver there will be one switch near to the driver for opening and closing the container. The system is an automated process, sensors are used for detecting and vacuum cleaner is used for sucking the dust particles. Here we use microcontroller-ATMEGA8/ATMEGA16, IR sensor,vacuum cleaner,beeper,power supply,flash programmer as hardware requirements and AVR studio, embedded C, MATLAB, sinaprogram as software requirementsAVR studio is the platform where we will write the code and compile the code for validation.Sinaprogram is the platform in which we will jump our code from PC to microcontroller

**V. BLOCK DIAGRAM**

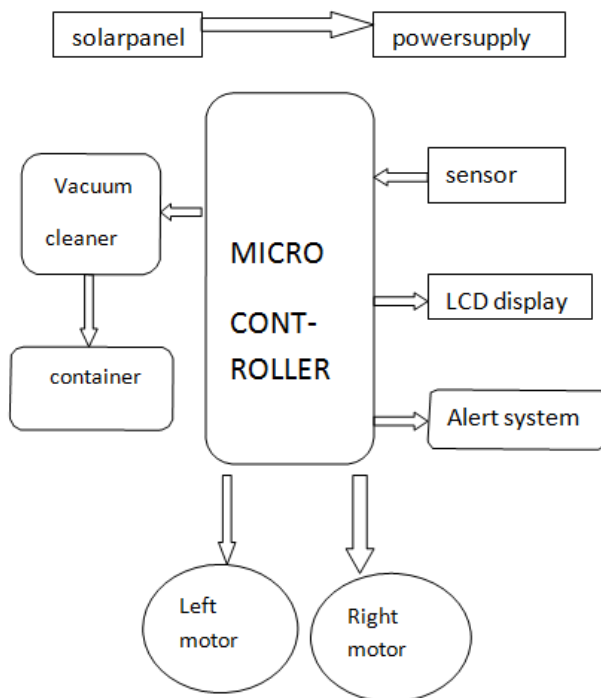

**6.1 Components Required**

Fixed resistor-Resistor is a passive component used to control current in a circuit. Its resistance is given by the ratio of voltage applied across its terminals to the current passing through it. Thus a particular value of resistor, for fixed voltage, limits the current through it. They are omnipresent in electronic circuits.The different value of resistances are used to limit the currents or get the desired voltage drop according to the current-voltage rating of the device to be connected in the circuit. For example, if an LED of rating 2.3V and 6mA is to be connected with a supply of 5V, a voltage drop of 2.7V (5V-2.3V) and limiting current of 6mA is required. This can be achieved by providing a resistor of 450 connected in series with the LED.

Resistors can be either fixed or variable. The low power resistors are comparatively smaller in size than high power resistors. The resistance of a resistor can be estimated by their color codes or can be measured by a multimeter. There are some non linear resistors also whose resistance changes with temperature or light. Negative temperature coefficient (NTC), positive temperature coefficient (PTC) and light dependent resistor are some such resistors. These special resistors are commonly used as sensors.

**VI.WORKING PRINCIPLE**

Our proposed system consists of micro controller which controls the whole process. The system will be fitted on bus, where vacuum cleaner is present for sucking the

**Capacitor-** A capacitor is a passive two terminal electrical component used to store energy in an electric field. The forms of practical capacitors vary widely, but all contain at least two electrical conductors separated by a dielectric (insulator); for example, one

common construction consists of metal foils separated by a thin layer of insulating film. Capacitors are widely used as parts of electrical circuits in many common electrical devices. When there is a potential difference (voltage) across the conductors, a static electric field develops across the dielectric, causing positive charge to collect on one plate and negative charge on the other plate. Energy is stored in the electrostatic field. An ideal capacitor is characterized by a single constant value, capacitance, measured in farads. This is the ratio of the electric charge on each conductor to the potential difference between them. The capacitance is greatest when there is a narrow separation between large areas of conductor, hence capacitor conductors are often called "plates," referring to an early means of construction. In practice, the dielectric between the plates passes a small amount of leakage current and also has an electric field strength limit, resulting in a breakdown voltage.

**Transistor** -When we talk of transistor in robotics, we talk about the cut off and saturation region only, while in your course you study transistor in active region. So here I am talking about transistor as a switch. When we say transistor as a switch, we talk of cut off or not because the typical cut off Voltage is around 5V and the saturation voltage ( $V_{be}$ ) is around 8V. There are regions between them. Let's start with transistor to glow an LED. Connect this circuit and see. Connect multimeter at the base of the transistor and see the voltage. In this circuit we can see that  $V_e = V_{be}$ . For the transistor to be switched ON  $V_e = .5V$ . Vary the potentiometer to make  $V_{be} = .5V$ , you can see that LED starts glowing (but it is less brightness). Vary the potentiometer to make  $V_{be}$  to around .8V, you can see that the LED brightness increases. This is because when  $V_{be} = .5V$  it starts with cut off and when  $V_{be} = .7V$  in active and  $V_{be} = .8V$  it becomes saturation region. Transistor is a current controlled device. In active region  $I_c = h_{fe} I_b$  and in saturation region  $I_c > h_{fe} I_b$ . That is why the brightness of the LED changes.

### VII. ADVANTAGES

It creates Eco friendly environment. Automation system for cleaning of road (no human effort for cleaning road). Less cost for cleaning city than manual human effort. City can be kept clean.

### VIII. FUTURE ENHANCEMENT

Separation of dry and wet particles which is in the container. The trash collected wet particles can be recycled and used for agriculture. Smart dustbin can be used.

### IX. CONCLUSION

It is impossible to clean the city roads. Cleanliness can be done by transportation means. The project is aimed to design and implement to where less manual power is used for cleaning city which is automatically cleaned by Buses, it is important for facility heads to primarily understand the need for professional cleaning equipment as an essential pre-request for better work environment so one of the most common equipment used for commercial application in any premises is the vacuum cleaner, ecofriendly Environment, automation system for cleaning of road, less Cost for cleaning city than manual human efforts.

### REFERENCE

1. <https://www.google.co.in/webhp?sourceid=chrome-instant&ion=1&espv=2&ie=UTF-8#q=google+wikipedia>