

Quantum Computing's Strength and Weakness

^[1]Dinesh Kumar Baghel

^[1]Department of Computer Science and Engineering, Galgotias University, Yamuna Expressway Greater Noida, Uttar Pradesh

^[1]dinesh.baghel@Galgotiasuniversity.edu.in

Abstract: Computers have developed especially from last 50 years. The current computers are extremely little, quick, amazing and vitality effective. In any case, this development has a farthest point. Presently researchers are taking a shot at a totally new sort of computer dependent on the Quantum material science rules. These computers are called quantum computers. The Quantum computers can take care of numerous issues which are not reasonable by the present traditional computer systems. The huge scale generation of the Quantum computers will begin soon, which will absolutely change the computers and this, will influence each field. To give gigantic taking care of capacities to current standard computer has delivered the possibility of quantum figuring. Quantum registering is a completely unique technique for building computer using quantum mechanics. By applying laws of quantum mechanics for computation has exponentially speeded up the dealing with capacities over old style material science. Quantum processing is another course of action of equipment for computer analysts, researchers, programming designers to make and overhaul figuring capacities far better than that can do with conventional registering.

Keywords: Computation, Quantum Computers, Qubit, Strengths and Weaknesses.

INTRODUCTION

Quantum computational intricacy is an energizing new zone that addresses the establishments of both hypothetical software engineering and quantum material science. The computational intensity of quantum Turing machines (QTM) has been investigated by a few scientists and numerous analysts and organizations are chipping away at it right now. Early work done by scientist told the best way to use some intrinsically quantum mechanical highlights of QTM. Their outcomes and the later research results by specialist set up the presence of prophets under which there exists some computational issues that QTM can fathom in polynomial time with conviction, though on the off chance that it is required a traditional probabilistic Turing machine to deliver the right answer with sureness, at that point it must require some investment on certain information sources[1].

Quantum computer works uniquely in contrast to the

customary computers. The customary computers can take a shot at and figure just a single exchange at once. Then again the quantum computers can deal with and play out various exchanges simultaneously which speed up more than customary computers. The reserve amental building square of a quantum computer is Qubit as appeared in the chart.

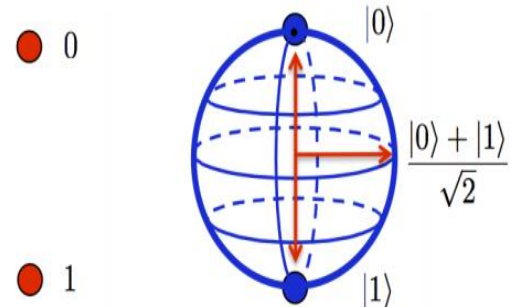

Classical Bit

Qubit

Figure 1: Classical Bit Vs Qubit

International Journal of Engineering Research in Computer Science and Engineering (IJERCSE)
Vol 4, Issue 12, December 2017

A standard piece can process or store 0 or 1 however a Qubit can work and work in the middle of the estimations of 0 and 1 (Figure 1, 2 and 3).

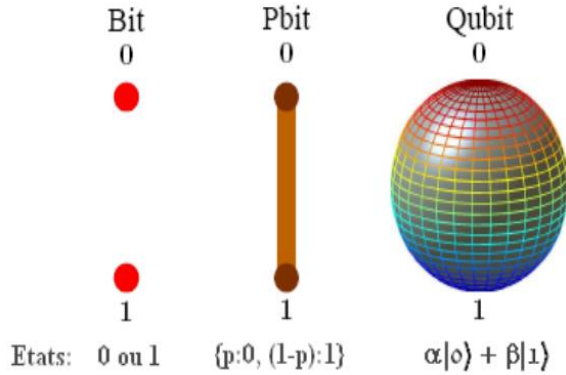

Figure 2: Difference between Advanced Piece and Qubit

Qubits Are Comprised Of Two Things Initially Is the Controlled Particles And Second One Is the Methods for Control

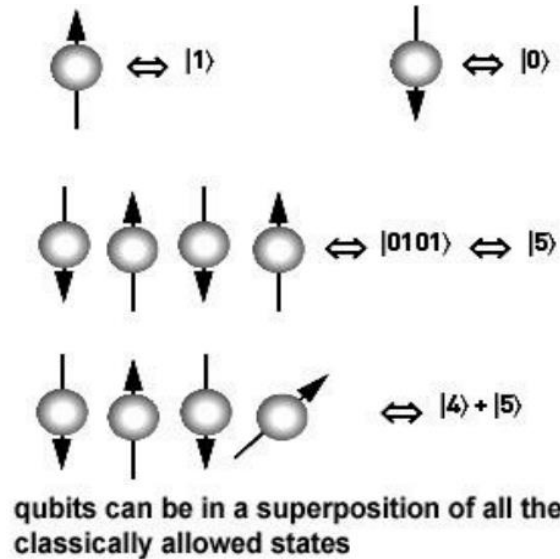

Figure 3: Qubits

The accompanying table will show the examination between the traditional registering and quantum processing (Table 1).

Table 1: Comparison of Traditional and Quantum Computing

S.No	Description	Classical Computing	Quantum Computing
1	Information storage and representation	0 or 1	Qubit
2	Delivery of information	Information can be copied without distributing.	Information cannot be copied distributing
3	Behaviour of information	Unidirectional	Multidirectional
4	Security	Hacker can break into communication	Hacker cannot break into communication.
5	Noise Tolerance	Noisy channel can be used to deliver the information.	Noiseless channel is required.
6	Computation Cost.	Directly proportional to the computation	Not Directly proportional to the computation

REVIEW AND RELATED WORK:

A Large 3-Dimensional bunch cross section is utilized as asset for quantum computer to process data and it is likewise utilized in centralized server

computers. This is the thought which can prompt a development of 7.5 billion photonic chips Quantum Computer[2].

The computer models which are persuaded by material science identify with both of the systems. These have both physical just as computational understanding. Quantum mechanics speak to a large portion of our understanding which is identified with infinitesimal physical wonders and the activities of a computer ought to likewise be in type of quantum mechanics.

Quantum figuring is still at advancing stage and nobody yet knows when its prerequisites will be met, climate a few tradeoffs will be made or inquire about on totally new way will started. It is suggested that how unequivocal minutely models of quantum computer register can be made and circle models fortified with the first and second kind can be utilized to speak to quantum register (Figure 4).

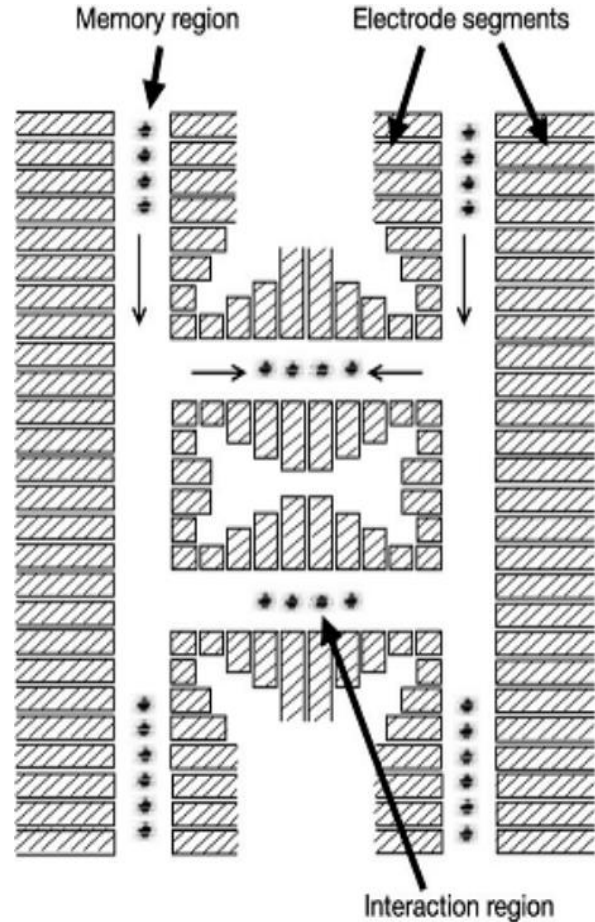

Figure 4: Quantum Charged Coupled Device (QCCD)

Particle traps can be utilized as the structure square of quantum computers. So what is a particle? A particle is a molecule that has lost at least one of its electrons. A particle trap is a system which comprises of electric and attractive fields, which can catch particles and keep them at areas. Utilizing a particle trap, one can organize a few particles in a line, at ordinary interims (Figure 5).

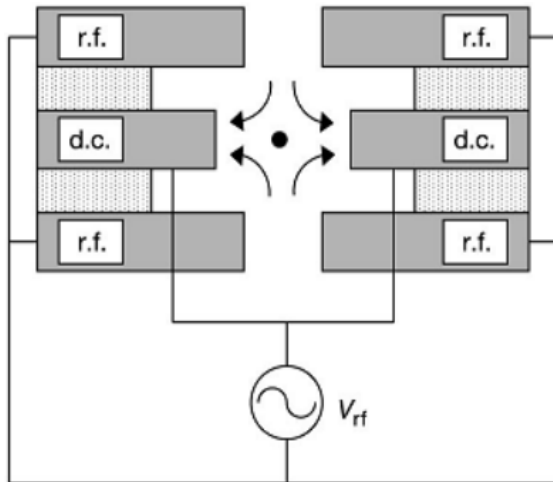

Figure 5: Configuration of static and radio frequencies for QCCD.

History of Quantum Computing:

In 1982, the Nobel Prize champ material science researcher Richard Feynman brainstormed the possibility of a quantum computer. He thought it as a computer that can utilize the impacts of quantum mechanics to further its potential benefit. A quantum computer would have the option to decipher the codes more rapidly than any standard traditional computer.

In 2000 March, Scientists from Los Alamos National Laboratory declared that they have prevailing to build up a 7-qubit quantum computer with a solitary drop of fluid[3].

In 2001 IBM and Stanford University researchers effectively encountered Shor's Algorithm on a quantum computer. The Shor's Algorithm is utilized to locate the prime components of numbers. These researchers utilized a 7-qubit computer to figure the elements of number 15. The computer accurately determined that the prime variables were 3 and 5. In 2006 Scientists in Waterloo and Massachusetts build up approaches to control a 12-qubit system. They found that Quantum calculation related control turns out to be increasingly more perplexing as all expansion the quantity of Qubits. In 2007 Canadian base quantum computer fabricating organization D-

Wave made a 16-qubit quantum computer. This quantum computer tackled many example coordinating issues.

QUANTUM LANGUAGES:

QCL (Quantum Computer Language) is the most exceptional actualized quantum programming language. Its sentence structure is like the grammar of the C programming language and old style information types are like information types in C. Quantum Computation includes some new ideas which are identified with the development of the particles like snare. So the Quantum programming language ought to have the option to manage these ideas. Routinely the quantum dialects are characterized at the low level and which debilitates the typical programming rehearses so another high language is depicted which has appropriate properties of a language. The Quantum Languages are consistently developing and new measurements are being included bringing about more structures and elevated level dialects yet at the same time there is parcel to do[4].

High Performance Quantum Computing:

Different issues which need gigantic computational force and are unsolvable now days with old style computers will be explained by elite Quantum registering. The High execution registering will be conceivable and this will bring about enormous activities 15 1 10 x skimming point tasks every second. Those super computers which will have forces of petascale during the handling of certain applications can reach to one quadrillion FLOPS. A calculation worked for this reason works well indeed. This calculation utilizes 1 to 2 QBIT doors works very well with IBM p690 having 1024 processors and 3TB of memory (Figure 6).

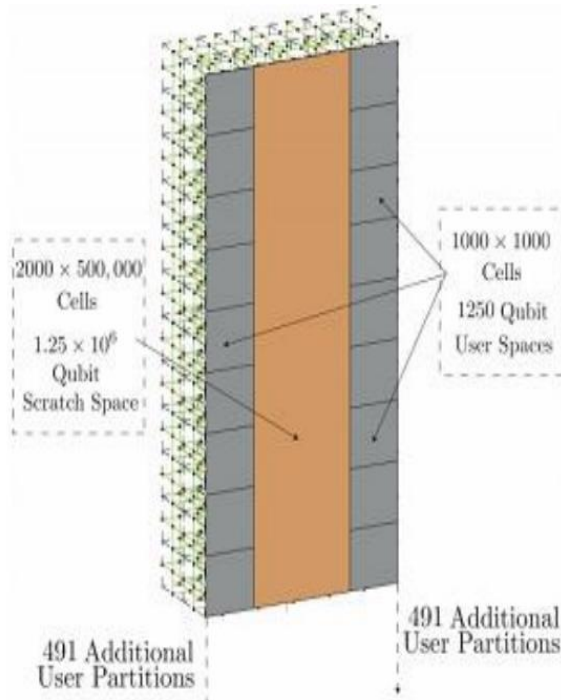

Figure 6: Partitioning of 3d Global lattice for a HPQC mainframe

The worldwide cross section appeared above measures 4000 x 500,000 unit cells and it is readied utilizing roughly 7.5×10^9 photonic chips. The cross section have started the possibility of a High Performance Quantum Computer, the quantum computer utilizes a 3 dimensional bunch grid for preparing various client related data.

Capabilities And Limitations:

Quantum computers are a lot of amazing than traditional computers. The Quantum computer can take care of issues with no time which an old style computer can take a very long time to unravel. Quantum computers can play out various exchanges one after another when contrasted with the old style computers. This builds their capacity without a doubt. The creation of quantum computers will be progressive for entire humankind. It will lessen remaining task at hand and take care of issues with no time which now anybody can tackle in days or weeks[5].

Then again the quantum computers are as yet a fantasy and they are not as much adaptable yet. Everybody ought not to be too hopeful in regards to quantum computers since they may allow us to down. Since this is too soon to think about what will they do. Commotion twisting can prompt data defilement. Various usage of Quantum Computers have been grown however they are of restricted use and are made uniquely for specific kind of showing. Here are not many software engineering fields in which quantum computers can be utilized.

Cryptography and Quantum Computing:

The cryptographic strategies and system are more verified using Quantum cryptography as the standard structure needs one time key trade for a secured data trade which can be cultivated by the quantum correspondence channel. The convention is utilized for key trade is BB84 and the technique is partitioned in two phases. The correspondence between the two locales is done over a quantum and open channel separately. The convention identifies testing in the event that somebody attempted to hack the system with some high accuracy. The quantum superposition rule has empowered new capacities for data extraction and sharing which are definitely more than the customary methods. The quantum systems are inclined to irregularity. Because of irritations from the earth qubits can become debased which will bring about the loss of information. The present methods utilized in quantum correspondence does not have the gadgets which can recover the signs. Recovery will decrease the opportunity of ruined information. On the off chance that appropriate gadgets won't be utilized, at that point the first sign can be annihilated or totally changed, If by one way or another some method is created to intensify the sign then a similar strategy can be utilized for hacking the sign[6].

Quantum Algorithms

The quantum processing is connected with establishments of science and material science. Grover's quest utilizes diverse system for accelerating customary calculations on quantum computers. The Grover's inquiry calculation is significant calculation in quantum figuring. Other than search this

calculation can likewise be applied to numerous different issues and it can speed up to polynomial time. On the off chance that all are looking in a database a hunt accelerate by square root can make the system productive like web indexes site databases and so forth. Ideal quantum question calculations for venture booking is created alongside the improvement in sales rep issue quadratic degree quicker having maximal degrees of three, four or five[7].

Some open issues like Boolean lattice item with respect to tight time space tradeoffs and Boolean network vector and system item tradeoffs should be investigated for both old style and quantum computers. Exponential Congruence's Solution in polynomial time is additionally given in quantum processing. Everybody must discover $x, y \in F_q$ to such an extent that $afx + bgy = c$. Quantum computers can take care of this issue in polynomial time. To take care of same issue the best old style calculation requires exponential time. The quantum calculation of depends on the quantum calculations for discrete logarithms and looking. Old style blunder revising codes permit the discovery and amendment of bit-flips by putting away information repetitively. Most extreme plausibility disentangling for subjective straight codes is NP-finished in the most pessimistic scenario. However, for organized codes or limited blunder effective unraveling calculations are known. Quantum calculations have been planned to accelerate the disentangling of convolutional codes and simplex codes.

Security and Quantum Computing:

The best element of quantum computers is their security. Hypothetically, it's difficult to hack the quantum computer system. Quantum computers use eyewitness impact. In this if all attempt to quantify one parameter of a smaller scale molecule will modify another parameter. This marvel, should resolve the principle issue of old style interchanges. Each endeavor to keep an eye on a correspondence will modify the transmitted message. There are three fundamental reasons which make the Quantum cryptography substantially more secure than the

traditional calculation.

Initially the obscure quantum state can't be duplicated and nobody can exploit the obscure state. Furthermore any endeavor to figure and gauge the quantum state will make an aggravation in the system and any message which is captured by some spy will get contaminated. Tainted message will be of no utilization for anybody including beneficiary. Thirdly if some quantum property is estimated and transformed it is preposterous to expect to turn around it to unique state. These three properties offers capacity to the quantum calculation and make it secure from any meddler. Significant level research is required so as to institutionalize the quantum data to make related conventions for quantum figuring to make it accessible for open use. The equipment which will be required for quantum calculation will be like QKD correspondence systems. QKD and quantum both require beneficiaries and transmitters for frail signs[8].

Complexity and Quantum computation:

The intricacy class P is characterized to be the arrangement of issues resolvable by a Turing machine in polynomial time. Essentially anybody can characterize a quantum multifaceted nature class utilizing standard quantum computer or a quantum Turing machine. Along these lines, the intricacy class BQP is characterized to be the arrangement of issues feasible by a quantum computer in polynomial time with limited blunder. The multifaceted nature hypothesis experts give a ton of significance to the Quantum calculation, they are chipping away at the computational unpredictability as well as on quantum intelligent evidence systems and quantum related NP. There are a few contentions which state that Church Turing issue can't be settled utilizing quantum Turing machines or quantum computers. The charts related quantum multifaceted nature is another zone of research. Quantum inquiry and quantum time intricacy is being examined as a piece of quantum multifaceted nature measures. The question intricacy of a diagram calculation alludes to the quantity of inquiries nearness rundown of the chart and quantum time multifaceted nature is identified with the

essential quantum tasks[9].

Practical Quantum Computers:

D-Wave Systems is a quantum computing organization, situated in Burnaby, British Columbia, Canada. The D-Wave One was based on early models, for example, D-Wave's Orion Quantum Computer. The model was a 16-qubit quantum annealing processor, showed on February 13, 2007 at the Computer History Museum in Mountain View, California. D-wave is first of its sort business quantum computing organization which is established in 1999. The D-Wave had labored for a long time just assembling data to how to manufacture a quantum computer. They concentrated on the most proficient method to configuration, assembling and scale the quantum computer into acknowledgment. Alongside the quantum computers various layers of the product are likewise structured so as to work on the new equipment and the design. The work has likewise accomplished for illuminating the business scale related learning, characterization and improvement issues. D-Wave has multiplied the quantity of qubits every year, and in 2013 they transported their 512-qubit D-Wave Two™ system. In 2015 they declared general accessibility of the 1000+ qubit D-Wave 2X™ system. The clients of D-Wave incorporate Google, NASA and University Of Southern California (Figure 7)[10].



Figure 7: D-Wave Quantum Computer

Since 2013, Google researchers have been trying a quantum computer acquired from D-Wave. The new investigation shows that the updated machine Google got not long ago, the D-Wave 2X, utilizes quantum stunts to take care of certain issues 100 million times as quick as an Intel processor running a specific sort of calculation. Broad research is going on at University Of Waterloo with respect to quantum mistake adjustment and adaptation to non-critical failure, quantum multifaceted nature, quantum calculations, quantum data hypothesis, turn based quantum data, non-gadgets related quantum data preparing, optical data handling identified with quantum hypothesis and quantum cryptography. The analysts at Waterloo University are chipping away at the laws of nature identified with quantum hypothesis so new ground-breaking innovations can be created which in result will help in creating future economies (Figure 8).

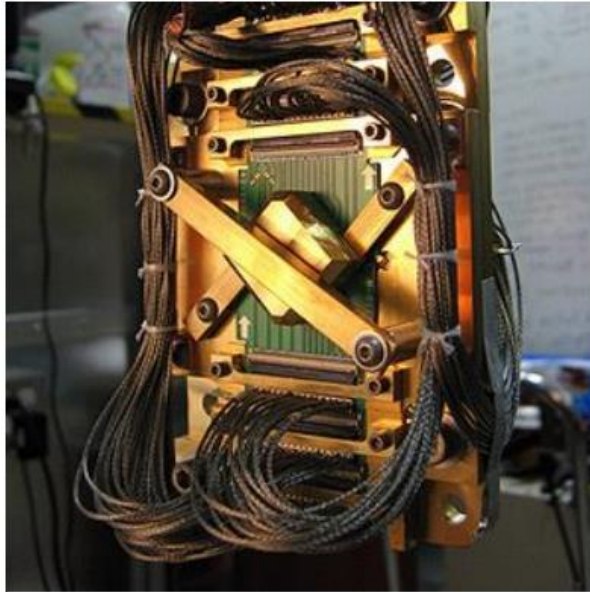

Figure 8: Quantum Leap Chip, The Heart of D-Wave's Computers

HOW QUANTUM COMPUTING WILL CHANGE EVERYTHING

Besides quantum computers could proclaim radical changes for the accompanying regions: Safer planes: Jet programming that is right now unreasonably complex for old style computers. Lockheed Martin intends to utilize its D-Wave quantum computer for this reason. Find far off planets: Quantum computers will have the option to dissect the huge measure of information which is gathered by telescopes and spaceships. Quantum computer can look through Earth-like planets from that information. Lift GDP: By utilizing customized commercial, in view of quantum calculation will empower purchaser spending which will support GDP. Distinguish malignancy prior: Quantum computational models will help decide how sicknesses create. So specialists will have the option to recognize disease at beginning periods.

Assist vehicles with driving themselves: Google is taking a shot at this task as of now that can recognize autos from tourist spots. Diminish passings from

cataclysmic events: Precision gauging will give individuals more opportunity to seek shelter and this will lessen passings from any calamity. Grow increasingly powerful medications: By examining DNA-sequencing information, specialists will find and structure predominant medication based medicines.

CONCLUSION

The quantum computers are the future of processing. Quantum processing is an incredible possibility and it will take care of numerous issues which can't be comprehended by traditional registering. It will likewise diminish the hour of critical thinking for the issues which are currently feasible by old style registering. The equipment and projects identified with Quantum figuring are not yet constructed totally. These are advancing yet soon it will end up being a reality and will change the innovation around the world. Numerous innovation goliaths like Google, IBM, Microsoft and the monster of processors Intel is additionally taking a shot at quantum figuring and they are burning through a large number of dollars on examine. They are exploring on building equipment and calculations for the quantum computers. The work is additionally being done in connection to the security and multifaceted nature of the quantum calculation so as to get secure and solid quantum systems.

At the point when they will prevail with regards to building Quantum computers, quantum computers will change the whole idea of figuring. The speed, the force the time everything will be changed incredibly. The equipment, programming dialects and calculations will likewise change. The measures for security, multifaceted nature and cryptography will likewise change. There will be progressively secure systems with less hacking possibilities. In spite of the fact that it is an awful news for programmers. It will make part of new chances and occupations to computer researchers. It will likewise give advantage to the organizations since quantum computer can foresee the monetary market more precisely than traditional computers. It will create more cash for business people. The issues which appear not feasible

through customary processing stand an excellent opportunity to give results utilizing quantum registering. Each field of life including research, instruction, designing, air space, therapeutic, innovation, media, atomic innovation, space travel, military and sports, in actuality each field of life will be influenced by the quantum computers.

REFERENCES

1. E. Gull, A. J. Millis, A. I. Lichtenstein, A. N. Rubtsov, M. Troyer, and P. Werner, "Continuous-time Monte Carlo methods for quantum impurity models," *Rev. Mod. Phys.*, 2011, doi: 10.1103/RevModPhys.83.349.
2. J. T. Barreiro, "Atoms, ions and photons for quantum tasks: Strengths and weaknesses," in *Optics InfoBase Conference Papers*, 2014, doi: 10.1364/cleo_qels.2014.ftu3a.1.
3. M. Shiddiq, D. Komijani, Y. Duan, A. Gaita-Ariño, E. Coronado, and S. Hill, "Enhancing coherence in molecular spin qubits via atomic clock transitions," *Nature*, 2016, doi: 10.1038/nature16984.
4. C. D. Bruzewicz, J. Chiaverini, R. McConnell, and J. M. Sage, "Trapped-ion quantum computing: Progress and challenges," *Appl. Phys. Rev.*, 2019, doi: 10.1063/1.5088164.
5. M. Alizadeh, S. Abolfazli, M. Zamani, S. Baaaharun, and K. Sakurai, "Authentication in mobile cloud computing: A survey," *Journal of Network and Computer Applications*. 2016, doi: 10.1016/j.jnca.2015.10.005.
6. V. Chang, D. Bacigalupo, G. Wills, and D. De Roue, "A categorisation of cloud computing business models," in *CCGrid 2010 - 10th IEEE/ACM International Conference on Cluster, Cloud, and Grid Computing*, 2010, doi: 10.1109/CCGRID.2010.132.
7. L. Badger, R. Patt-corner, and J. Voas, "Cloud Computing Synopsis and Recommendations Recommendations of the National Institute of Standards and Technology," *Nist Spec. Publ.*, 2012, doi: 2012.
8. B. J. Erickson, P. Korfiatis, Z. Akkus, and T. L. Kline, "Machine learning for medical imaging," *Radiographics*, 2017, doi: 10.1148/rg.2017160130.
9. M. H. Kuo, A. Kushniruk, and E. Borycki, "Can cloud computing benefit health services?-A SWOT analysis," in *Studies in Health Technology and Informatics*, 2011, doi: 10.3233/978-1-60750-806-9-379.
10. S. Mandrà, Z. Zhu, W. Wang, A. Perdomo-Ortiz, and H. G. Katzgraber, "Strengths and weaknesses of weak-strong cluster problems: A detailed overview of state-of-the-art classical heuristics versus quantum approaches," *Phys. Rev. A*, 2016, doi: 10.1103/PhysRevA.94.022337.
11. Khaleel Ahmad, Monika Sahu, Madhup Shrivastava, Murtaza Abbas Rizvi and Vishal Jain, "An Efficient Image Retrieval Tool: Query Based Image Management System", *International Journal of Information Technology (BJIT)*, available online at 26th May, 2018, having ISSN No. 2511-2104.
12. Manjot Kaur, Tanya Garg, Ritika Wason and Vishal Jain, "Novel Framework for handwritten Digit Recognition Through Neural Networks", *3C Technology, Glosses of innovation applied to the SME*, ISSN: 2254-4143, Vol. 29, Issue 2, page no. 448 – 467.