

Motion Detection Using IOT Mechanism

^[1] Parashiva Murthy B M ^[2] Inchara S ^[3] Yashaswini K K

^[1] Assistant professor ^{[2][3]} Student

^{[1][2]} Department Of CSE, GSSS Institute of Engineering & Technology for Women, Mysuru

^[1]Parashivamurthy89@gmail.com ^[2]sonyinchara@gmail.com

Abstract: Internet of things is the communication of anything with any other thing, the communication mainly transferring of useable data, for example a sensor in a room to monitor and control the temperature. It is estimated that by 2020 there will be about 50 billion internet-enabled devices. This paper aims to describe a security alarm system using low processing power chips using Internet of things which helps to monitor and get alarms when motion is detected and sends photos and videos to a cloud server. Moreover, internet of things based application can be used remotely to view the activity and get notifications when motion is detected. The photos and videos are sent directly to a cloud server, when the cloud is not available then the data is stored locally on the Raspberry Pi and sent when the connection resumes. Therefore, advantages like these make this application ideal for monitoring homes in absence.

Index Terms— -Internet of Things, Motion detection

I. INTRODUCTION

In the present world where we live there are already devices, which are connected to each other and help in day to day aspects, for example wearable fitness devices, sensors which help in automatic garages, RFIDs in ID cards used in Universities and Industries to gain and lock access. However, imagine this after a few years where billions of devices will be connected to each other including cars, phones, jet planes, appliances, wearable gear etc. Internet of Things (IoT) is an going development of the Internet by which everyday 'things' objects have communication capabilities which allow them to send and receive data.

It is expected to connect systems, devices, sensors which can communicate without the need of machine-to-machine communication. IoT refers to an enormous variety of devices such as sensors that assist fire fighters in rescue and search operations, heart beat and blood pressure measuring devices, bio-chips that are implanted in farm animals.

The Internet of things presently is being used in the fields of automobiles, agriculture, security surveillance, building management, smart-homes, and health care. The IoT expects to use low-cost computing devices where there is less energy consumption and limited impact to the environment.

The project aims to simplify motion detection and the interface to be user friendly, which would send prompt notifications when motion is detected. The main limitation of Internet of things is that as the devices have limited computing power the security aspects come in question as the transmitted and received data cannot be encrypted and decrypted. However, Internet of things offers many advantages that overcome this disadvantage. The IoT will revolutionize everyday life and help in situations like managing airports' passenger flows, smart homes, heating buildings, caring for the elderly. In the present world where we live there are already devices, which are connected to each other and help in day to day aspects, for example wearable fitness devices, sensors which help in automatic garages, RFIDs in ID cards used in Universities and Industries to gain and lock access. However, imagine this after a few years where billions of devices will be connected to each other including cars, phones, jet planes, appliances, wearable gear etc. The IoT has its own challenges, which need to be addressed. Every device will require an IP address to communicate, the present IPv4 has only 4.3 billion unique addresses, which will be exhausted soon and hence we will need to adapt to IPv6. The next challenge would be data storage, as billions of devices are connecting the data would need to be stored for which massive storage space is required. After the data have been collected we need to make sure that the security policies are in place as more and more personal information will be collected from devices which not get breached and the data should not get in the hands of hackers. Privacy would also

be a great challenge as after the recent hacks people are becoming more concerned about their privacy. Hence these challenges need to be taken in careful consideration before planning any project related to the IoT. In this project of motion detection these security challenges have been considered after which a successful implementation has been tested

II. AIM AND OBJECTIVE

The main aim of this project is to use the IoT concept using Cloud Server to transfer the images. As per the analysis results and estimation, in next 5 years, we are expected to have million of devices communicating with internet. This helps the organization and end user to keep the track record of the information.

In this project we are working on the security applications. In present scenario or in India (cities), every house or shops are implemented with CCTV cameras. The objective of this project is to capture an image when any intruder motion is detected in prevented or secured areas. This is implemented by using Raspberry Pi-2 kit.

III. NEED FOR PROJECT

Incorporating IoT in our lives has many advantages helping individuals, businesses and on everyday basis. Health, safety, security are some forms in which new concepts are emerging in IoT. It can be very beneficial to integrate IoT into security systems and this project aims to integrate IoT in security systems to detect motion, for example everyday when you are at work you will be able to monitor and get notifications if any activity happens at your home. The other major advantage that this system will have over the others is that it will make the users system lightweight for example at present these are possible but not without machine-to-machine communication. In this case there is no need to have machines at both ends to get the desired output. Thus for home users this system will prove to be of great use as it has low energy consumption and also comes at a low cost .

IV. MOTION DETECTION

The primary functions of our project are: Detect Motion. In this a python script would analyze the video, if there is a difference from the last frame it would be flagged and video recording and snapshots generation will begin.

Customize Attributes: The user will have the capability to customize the settings for frames per second, resolution, brightness, contrast, saturation etc. On Motion Detected: The user has the option of customizing the action when motion is detected, for example the option used when

testing the project was a script, that was executed on the Raspberry Pi to send an email, hence as the motion was detected the end user received an email and he could do the needful, for example login to the camera and see the movement. On Picture/Movie Save: The user has the option that when a snapshot/video is saved, by default it is saved locally but the user can customize to send it to a ftp server or SFTP server or cloud managed service such as Drop box, which supports command line LINUX based commands. The pictures/videos are saved instantly if there is a breach in the house and the person tries to remove the setup still the pictures/videos would have already been stored to an external server as configured.



V. RASPBERRY PI - AN INTRODUCTION

Raspberry Pi: It is credit card sized computer, which can plug into any HDMI input device or RCA video input device and a keyboard is required for operation. Once it is initialized the HDMI and keyboard are also not required for its operation as you can then operate it by other means such as ssh for command line interface and VN C if graphical user interface is desired. The main technical specifications of the latest model of Raspberry Pi also known as Model B have the following features: • 700 MHz ARM CPU

- 512MB SDRAM
- 10/100 Ethernet RJ45
- 2 x USB 2.0
- HDMI (1.4) and Composite RCA



Raspberry pi –model b

The Raspberry Pi runs Linux based operating systems and there is a specialized version of Linux based kernel known as Raspian which can run almost all programs which are Linux compatible. Hence in this project we have used 'python' and 'wput', script written in python for motion detection and wput for storing the files on an external server

A. Advantages

The Raspberry Pi being small as a credit card server still has the capabilities of working as a normal computer it can play 1080p resolution videos without lagging. It has a low price relatively as compared to machines in the market and can serve as a server for light traffic such as web traffic or DNS servers or NTP servers, which can run on low power also for example it can be powered by portable batteries which can act as UPS (uninterrupted power supply).

B. Disadvantages

Although Raspberry Pi can perform discrete tasks, it has some limitations due to its hardware. Firstly, it cannot run x86 operating systems such as Windows and some Linux distributions. Secondly, it cannot run applications, which require high CPU utilization. "Model B took 107ms to complete one calculation of the purely synthetic prime number test; a mid-range desktop Core 2 Duo ES400 took only 0.55ms." [2] Hence we can state that it can be used for specific purposes but it is not designed to replace the personal computer. (power supply), when there is a power cut and notify about the power cut to the network administrators.

VI. PROJECT ARCHITECTURE

This project uses a triple-layered architecture. The first layer is the motion detection layer, which is the outcome by the python script and then in the second layer the actions are triggered as per the configuration file. In the third layer the actions triggered are executed for example

- sending email to the user saving the pictures/videos to the ftp/sftp server. The important components of the project are described as below: 1.A script to detect motion. In this project a python script has been used.
- 2. Python compiler to handle the request.
- 3. Storage to store the temporary files.
- 4. Notification methods such as email scripts used in this project.
- 5. External server to store files, ftp server used in this project.

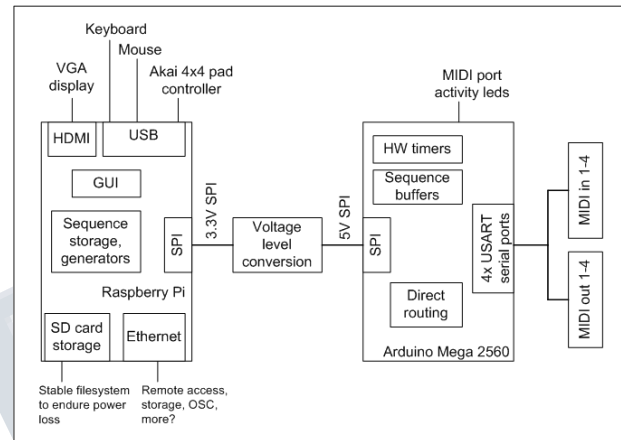

Project architecture

VII. PROJECT IMPLEMENTATION

While developing any project it is important to decide the architecture of the project and the capacity and capabilities of the hardware being used. In this project we have used a Raspberry Pi Model B to connect the web camera to capture the footage and the RJ45 to connect to the Internet for sending and receiving data. Raspberry Pi executes the processing of all the data and after the data is analyzed then the set actions are triggered for example sending an email on detection of motion and uploading images and videos to the ftp server. The python script matches the last frame and the present frame of the live video, if there is any difference then the motion flag is set, triggering all the events.

The python script executes and takes continuous snapshots from the camera till the motion is detected, it also starts to make a video of the same from the start till the end, 133 continuous photos are uploaded to the external server, as there could be a chance that the person would attempt to damage the device itself. As the user would also get a notification of the motion detection they can login remotely to the Raspberry Pi and check live output from the camera, which would verify the reason for the detection

of motion.

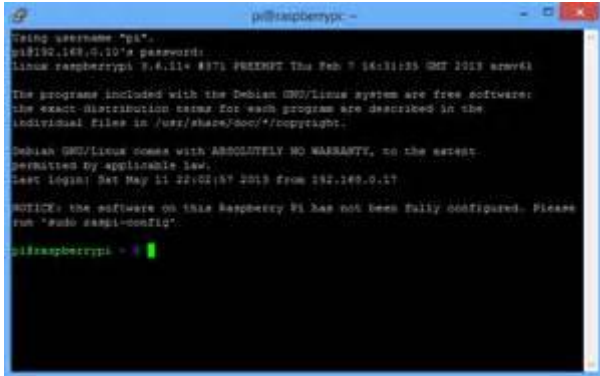

```

pi@raspberrypi ~
┌───( sshpass -c pi@raspberrypi:~ )───┐
│                                     │
│ Using username "pi".               │
│ pi@192.168.0.10's password:         │
│ Linux raspberrypi 3.6.11+ #371 PREEMPT Thu Feb 7 16:31:35 GMT 2013 armv6l │
│                                     │
│ The programs included with the Debian GNU/Linux system are free software; │
│ the exact distribution terms for each program are described in the        │
│ individual files in /usr/share/doc/*/copyright.                             │
│                                     │
│ Debian GNU/Linux comes with ABSOLUTELY NO WARRANTY, to the extent        │
│ permitted by applicable law.                                               │
│ Last login: Sat May 11 22:02:57 2013 from 192.168.0.17                      │
│ NOTICE: the software on this Raspberry Pi has not been fully configured.  Please │
│ run "sudo raspi-config".                                                    │
│                                     │
│ pi@raspberrypi ~ ──┘

```

VIII. USE OF PROJECT

The purpose of the project is to make a system, which would detect and take snapshots and videos of the motion when detected and upload to an external server. The major use of the 'Motion Detection' is at homes, buildings and also for surveillance for security for example of server rooms. This equipment when made on a large scale would be much cheaper and would cost under 60\$ which is relatively very cheap to current products which have similar capabilities. The notification can also be done via text messages on mobiles using a text gateway on the Raspberry Pi. The options are unlimited for notification and storage of the files depending on the user's requirements, presently almost everyone has an Internet connection at home and all the members in the family are away during the day, as security systems are not affordable this system would be great alternative to implement.

IX. CONCLUSION

Henceforth, by enhancing the capabilities of these technologies and integrating them, we hope to introduce the 'Motion Detection' system and to contribute to the current security system. This system would be an alternative for expensive security systems being used in the present day. This system does not require any special modifications to the infrastructure where installation is required and can be implemented without any hassle. I have tested this system for 180 days and have found 99.9% accurate notifications and results.

REFERENCES

[1] C. Pfister, Getting Started with the Internet of Things. Sebastopol, CA: O'Reilly Media Inc., 2011.

[2] M. Roelands et al., "Enabling the masses to become creative in smart spaces", in Architecting the Internet of Things, Berlin, Germany: Springer-Verlag, 2011, pp 38-

43.

[3] Zhuankun Wu. : Initial Study on IOT Security architecture. 1. Strategy and decision-making research (2010)

[4] HuanshengNing, Hong Liu. Cyber-Physical-Social Based Security Architecture for Future Internet of Things. J. Scientific research, (2):1-7 (2012)

[5] Xueguang Yang, Fengjiao Li, Xiangyong Mu, etc.: Design of security and defense system for home based on Internet of things. J. computer application. 30(12):300-318 (2010)

[6] A N. Ansari, S.Patil, ANavada, APeshave, Y.Borole, Online C/C++ Compiler using Cloud Computing II , Multimedia Technology (ICMT), July 2011 International Conference, pp. 3591-3594.

[7] Raspberry Pi Org. Forum [Online]. Available: <http://www.raspberrypi.org/phpBB3/>

[8] L. You-guo and I. Ming-fu, 'The Reinforcement of Communication Security of the Internet of Things in the Field of Intelligent Home through the Use of Middleware', 2011 Fourth International Symposium on Knowledge Acquisition and Modeling, 2011

[9] M. Koster. Tools for the open source Internet of things [Online]. Available: <http://iot-toolkit.com>

[10] Lu Tan and Neng Wang, 'Future internet: The Internet of Things', 2010 3rd International Conference on Advanced Computer Theory and Engineering (ICACTE), 2010.

[11] L. Atzori, A Iera, and G. Morabito, "The internet of things: A survey," Computer Networks, vol. 54, no. 15, pp. 2787-2805, 2010. 134

[12] Innovative Information Science & Technology Research Group, 'Innovative Information Science & Technology Research Group', 2014. [Online]. Available: <http://isyou.info>. [Accessed: 23- Jun- 2014]

[13] Haitao Liu. The Internet of Things Makes Life Better- a Visit of Haitao Hu, the Engineering Technology R &D Center Director of Chinese Academy of Sciences, Wuxi Sensor Network L. Shanghai standardization, 2010. 1.

[14] D.Guinard, V.Trifa, E.Wilde, "A resource oriented architecture for the web of things", in Proc. Of the Internet of Things (IOT 2010). SAP res., ETH Zurich, Zurich,

Switzerland, 2010.

[15] D. Chen, G. Chang, L. Jin, X. Ren, 1. Li and F. Li, 'A Novel Secure Architecture for the Internet of Things', 2011 Fifth International Conference on Genetic and Evolutionary Computing, 2011

[16] Z. Yu and W. Tie-Ning, 'Research on the Visualization of Equipment Support Based on the Technology of Internet of Things', 2012 Second International Conference on Instrumentation, Measurement, Computer, Communication and Control, 2012.

[17] INFSO 0.4 Networked Enterprise&Rfid, INFSO g. 2 Micro&Nano Systems, working group RFID of the ETPEPOSS, "Internet of Things in 2020 -- Roadmap for the future", 2008

